

General description

Pressure transducer HPSD 3000 is a pressure sensing device. Signal conditioning consists of complete temperature compensation and ASIC. High performance and accuracy enables use of this transducer in many applications. Programmable temperature compensation provides 0,5%FS total error over 0 to 70°C temperature range. Operating from single 5 V supply, wide compensated temperature range and standard, ratiometric 0,5 to 4,5 V output provides OEM users maximum freedom for any type of application with dry air or non-corrosive gases or liquids.

The model HPSD 3000 is designed for through hole PCB assembly with one or two pressure ports. The whole group consists for pressure ranges from **1 mbar to 7 bar**. Gage, differential and absolute versions are available for this group.

Features

- Single 5 V supply voltage
- **Total accuracy down to 0,5%FS** over 0 to 70°C, all effects included (maximum)
- Standard 0,5 – 4,5 V voltage output
- Up to 15 bits I2C output (pressure + temperature)
- High performance OEM applications
- Pressure ranges **from 1mbar to 7 bar**
- Gage, differential and absolute pressure configurations.

Applications

- HVAC
- Medical instrumentation
- Respirators
- Air flow monitoring
- Process control
- Pneumatics control

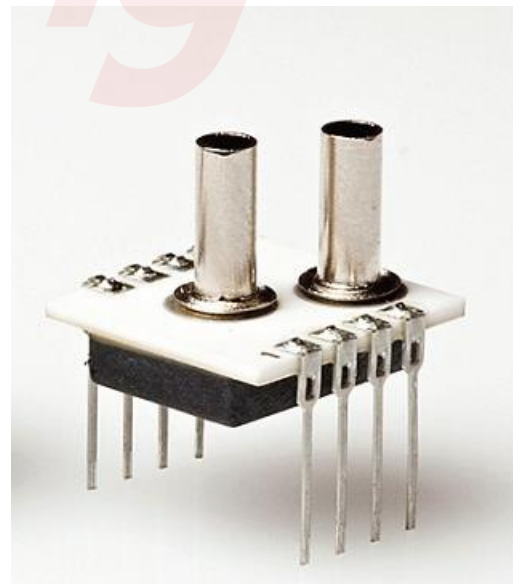

This information applies to a product under development. Its characteristics and specifications are subject to change without notice. Hyb d.o.o. assumes no obligation regarding future manufacture unless otherwise agreed to in writing. Copyright © Hyb d.o.o., 2017. All rights reserved.

Available types overview
T_{AMB}=25°C, V_{CC} = 5V unless otherwise noted.
Ultra low pressure range

Pressure range	1 mbar (100 Pa)	2.5 mbar (250 Pa)	5 mbar (500 Pa)
ID group	HPSD 3000-001M	HPSD 3000-2P5M	HPSD 3000-005M
Pressure types	differential/gage/ bidirectional differential	differential/gage/ bidirectional differential	differential/gage/ bidirectional differential
V _{OUT}	0,5 to 4,5 V	0,5 to 4,5 V	0,5 to 4,5 V
Temperature ranges	Operating: -25 to 85°C, Compensated: 0 to 70°C, Storage : -40 to 125°C		
Over pressure ¹⁾	100 mbar	100 mbar	100 mbar
Burst pressure ²⁾	150 mbar	150 mbar	150 mbar

Low pressure range

Pressure range	10 mbar (0,15 psi)	20 mbar (0,3 psi)	50 mbar (0,8 psi)	100 mbar (1,5 psi)
ID group	HPSD 3000-010M	HPSD 3000-020M	HPSD 3000-050M	HPSD 3000-100M
Pressure types	differential/gage/ bidirectional differential	differential/gage/ bidirectional differential	differential/gage/ bidirectional differential	differential/gage/ bidirectional differential
V _{OUT}	0,5 to 4,5 V	0,5 to 4,5 V	0,5 to 4,5 V	0,5 to 4,5 V
Temperature ranges	Operating: -25 to 85°C, Compensated: 0 to 70°C, Storage : -40 to 125°C			
Over pressure ¹⁾	100 mbar	200 mbar	500 mbar	1000 mbar
Burst pressure ²⁾	150 mbar	300 mbar	750 mbar	1500 mbar

High pressure range

Pressure range	350 mbar (5 psi)	1 bar (15 psi)	2 bar (30 psi)	4 bar (60 psi)	7 bar (100 psi)
ID group	HPSD 3000- 350M	HPSD 3000- 001B	HPSD 3000- 002B	HPSD 3000- 004B	HPSD 3000- 007B
Pressure types	differential/gage/ bidirectional differential	differential/gage/ bidirectional differential/ absolute	differential/gage/ bidirectional differential/ absolute	differential/gage/ bidirectional differential/ absolute	differential/gage/ bidirectional differential/ absolute
V _{OUT}	0,5 to 4,5 V	0,5 to 4,5 V	0,5 to 4,5 V	0,5 to 4,5 V	0,5 to 4,5 V
Temperature ranges	Operating: -25 to 85°C, Compensated: 0 to 70°C Storage : -40 to 125°C				
Over pressure ¹⁾	1 bar	3 bar	6 bar	8 bar	14 bar
Burst pressure ²⁾	1,7 bar	5 bar	10 bar	12 bar	21 bar

This information applies to a product under development. Its characteristics and specifications are subject to change without notice. Hyb d.o.o. assumes no obligation regarding future manufacture unless otherwise agreed to in writing. Copyright © Hyb d.o.o., 2017. All rights reserved.

Performance characteristics
T_{AMB}=25°C, V_{CC} = 5V, unless otherwise noted.

Parameter	Symbol	Min.	Type	Max.	Unit
Power supply					
Supply voltage	V _{CC}	4,75		5,25	V
Current consumption	I _{CC}		4	6,5	mA
Analog output (pressure) ³⁾					
Offset voltage ⁴⁾	V _O		0,50		V
Full scale output (FSO) ⁵⁾	V _{FS}		4,50		V
Full scale span (FSS) ⁶⁾	V _{FSS}		4,00		V
Offset voltage (bidirectional devices)	V _O		2,50		V
Digital output (pressure), 15 bits ³⁾					
Offset voltage ⁴⁾	V _O		3277		counts
Full scale output (FSO) ⁵⁾	V _{FS}		29491		counts
Full scale span (FSS) ⁶⁾	V _{FSS}		26214		counts
Offset voltage (bidirectional devices)	V _O		16384		counts
Digital output (temperature), 15 bits ⁷⁾					
Temperature output @ 0°C	T ₀		8192		counts
Temperature output @ 70°C	T _s		24576		counts
Accuracy (pressure) @ 25°C ⁸⁾					
Ultra low pressure (1 to 5 mbar)	E _a		0,5	±1,5	%FSO
Low pressure (10 to 100 mbar)	E _a		0,2	±0,5	%FSO
Standard pressure (all other)	E _a		0,1	±0,3	%FSO
Total accuracy (pressure) @ 0 to 70°C ⁹⁾					
Ultra low pressure (1 to 5 mbar)	E _{ta}		1	±2	%FSO
Low pressure (10 to 100 mbar)	E _{ta}		0,5	±1	%FSO
Standard pressure (all other)	E _{ta}		0,3	±0,5	%FSO
Resolution					
A/D converter	D _i			15	bit
D/A converter	D _o		11		bit
Response time	E _{rt}		1,5		ms
Repeatability ¹⁰⁾	E _r		±0,05		% FSO
Nonlinearity & pressure hysteresis (BFSL) ¹¹⁾	E _l		±0,1	±0,3	% FSO
Load resistance	R _L	2		∞	k
Media compatibility		See spec. note ^{12), 13)}			
Weight	W		3		g

This information applies to a product under development. Its characteristics and specifications are subject to change without notice. Hyb d.o.o. assumes no obligation regarding future manufacture unless otherwise agreed to in writing. Copyright © Hyb d.o.o., 2017. All rights reserved.

Specification notes

- 1) Over pressure is the maximum pressure which may be applied without causing damage to the sensing element.
- 2) Burst pressure is the maximum pressure which may be applied without causing leakage damage to the sensing element.
- 3) Analog output signal is ratiometric to power supply V_{cc} , digital signal is not ratiometric to the power supply.
- 4) Offset voltage is the voltage output at zero pressure.
- 5) Full scale output is the voltage output at full pressure range.
- 6) Full scale span is the algebraic difference between the output at full scale pressure range and offset.
- 7) Digital output signal (temperature) is not ratiometric to power supply V_{cc} . Temperature data are read directly on the sensing element.
- 8) Accuracy includes all effects (offset, span, nonlinearity, pressure hysteresis and repeatability) at room temperature and represents maximum deviation of transducer signal from ideal characteristic.
- 9) Total accuracy includes all effects (offset, span, nonlinearity, pressure hysteresis and repeatability) included with all temperature effects of offset and span. It describes overall error and represents maximum deviation of transducer signal from ideal characteristic in compensated temperature range from 0 to 70°C.
- 10) Repeatability is defined as typical deviation of the output signal after 10 pressure cycles.
- 11) Nonlinearity is defined as the BFSL (best fit straight line) across entire pressure range.
- 12) Media compatibility: on pressure port P1: clean, dry and noncorrosive gases to silicon, RTV, ceramics Al₂O₃, Pyrex, LCP plastics, epoxy, solder, tin.
- 13) Media compatibility: on pressure port P2: noncorrosive gases or liquids to silicon, Pyrex, RTV, ceramics Al₂O₃, solder, tin.

Outline dimensions & Pinout

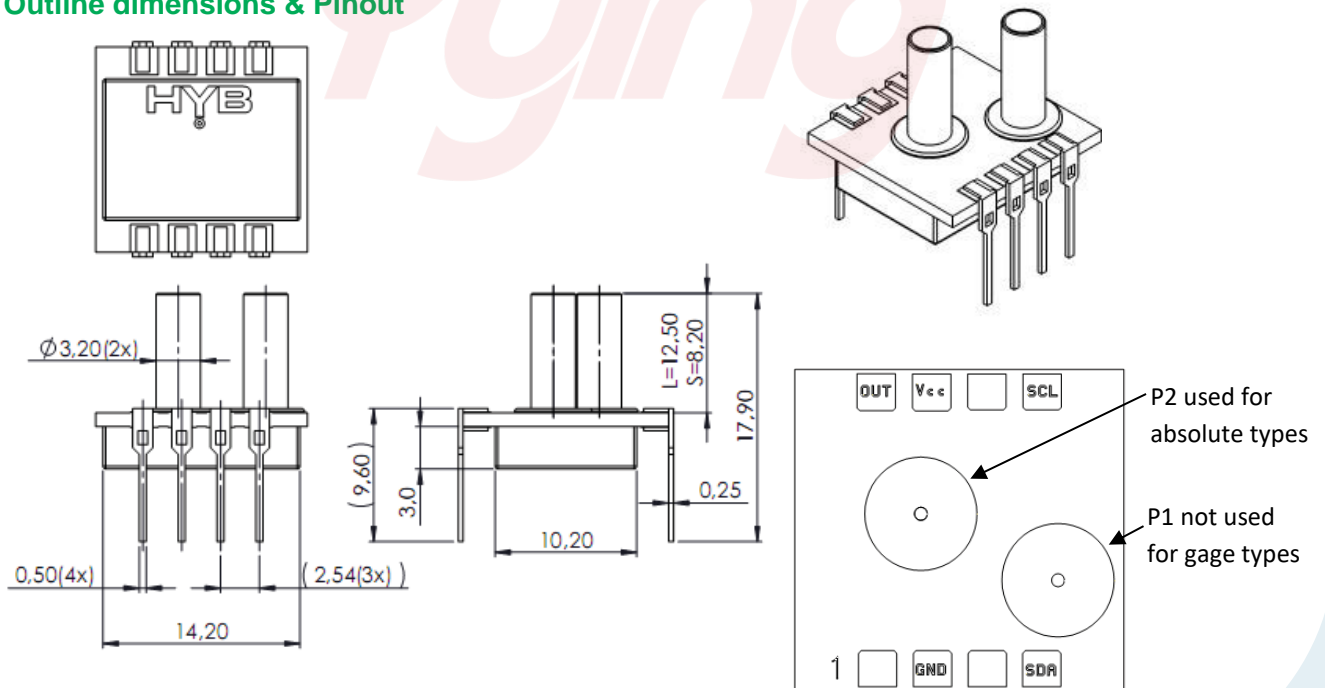

This information applies to a product under development. Its characteristics and specifications are subject to change without notice. Hyb d.o.o. assumes no obligation regarding future manufacture unless otherwise agreed to in writing. Copyright © Hyb d.o.o., 2017. All rights reserved.

Ordering guide

Transducer type	Pressure range	Pressure type	Pressure direction	Pressure port	Pressure tube
HPSD 3000	001M	D	0	P	S
	2P5M	G	B	N	L
	005M	A			
	010M				
	020M				
	050M				
	100M				
	350M				
	001B				
	002B				
	004B				
	007B				

Pressure range	
001M	1 mbar
2P5M	2.5 mbar
005M	5 mbar
010M	10 mbar
020M	20 mbar
050M	50 mbar
100M	100 mbar
350M	350 mbar
001B	1 bar
002B	2 bar
004B	4 bar
007B	7 bar

Pressure type	
D	Differential
G	Gage
A	Absolute (for p≥1 bar)

Pressure tube	
S	SHORT (8.3mm)
L	LONG (12.5mm)

Pressure direction	
0	0 to press. range
B	-press range to +press. range (bidirectional)

Pressure port	
P	Positive pressure on P1
N	Positive pressure on P2

Other configurations possible on special request.

This information applies to a product under development. Its characteristics and specifications are subject to change without notice. Hyb d.o.o. assumes no obligation regarding future manufacture unless otherwise agreed to in writing. Copyright © Hyb d.o.o., 2017. All rights reserved.