



US633-F1K-T4

Differential Pressure Sensor With I²C

Key Features

- ◆ Piezo-resistive silicon micro-machined sensor
- ◆ Differential type pressure sensor
- ◆ I²C Interface
- ◆ Pressure range: +/- 1000 Pa(Other Pressure Available)
- ◆ Pressure Sensitivity: 0.0027 Pa/LSB
- ◆ 24 Bit Σ - Δ ADC
- ◆ Temperature Compensation: -5 ~ 65 °C
- ◆ Operating voltage 3.0V
- ◆ Operating mode current: ~0.6mA (typical)
- ◆ Sleep Mode current: 20nA (typical)
- ◆ SOP16 Package
- ◆ RoHS compliant and Halogen-free

Applications

- ◆ Medical instrumentation
- ◆ Industrial pneumatic control
- ◆ Air Conditioning
- ◆ HVAC Application
- ◆ Home electricity appliances

Description

The US633 is the pressure sensor which measures differential pressures. It consists of a silicon micro-machined sensing element chip and a signal conditioning ASIC. The ASIC is equipped with a 24-bit resolution Σ - Δ ADC and outputs a highly precise pressure value as a digital value. The pressure sensor element and the ASIC are mounted inside a system-in-package and wire-bonded to appropriate contacts. The US633 provides digital output interface. It can achieve ESD robustness, fast response time, high accuracy and linearity as well as long-term stability. All measurement data is fully calibrated and temperature compensated. In addition, it allows for easy system integration.



US633-F1K-T4

Differential Pressure Sensor With I²C

Block Diagram

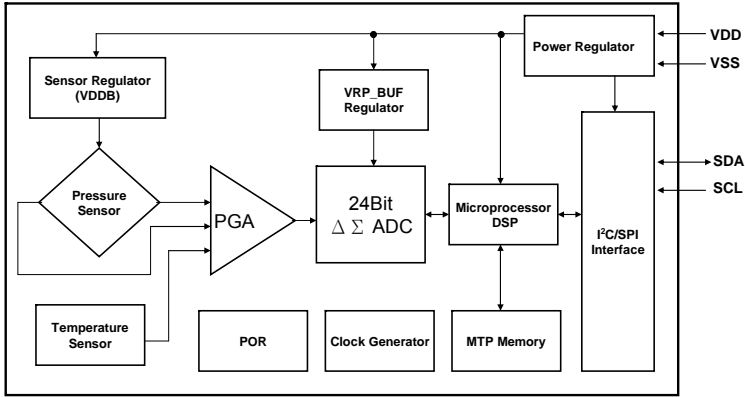

Pin Configuration

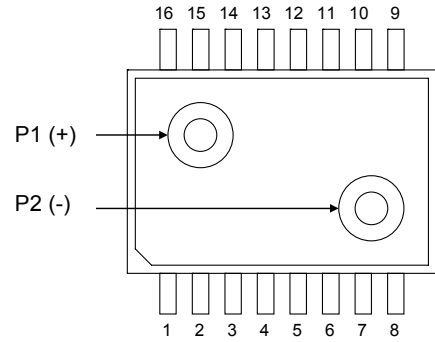

Top View

NOTE:

- (1) P1(+): Top side of the pressure sensor. If P1 > P2, the output value will be positive pressure.
- (2) P2(-): Back side of the pressure sensor. If P2 > P1, the output value will be negative pressure.

Pin Description

Pin No.	Pin Name	I/O	Function description
6	VSS	P	Connected to GND
7	VDD	P	Positive supply voltage
10	SDA	I/O	Data in/out for I ² C
11	SCL	I	Clock input for I ² C
1, 2, 3, 4, 5, 8, 9, 12, 13, 14, 15, 16	NC	—	No Connected.



US633-F1K-T4

Differential Pressure Sensor With I²C

Maximum Ratings (Voltage with respect to GND unless otherwise noted)

VDD	-0.4 V to +3.63 V
Voltage at Digital IO Pins.....	-0.5 V to VDD+0.5 V
Operating Temperature Range	-40°C to +85°C
Storage Temperature Range.....	- 40°C to +125°C
Electrostatic Discharge Tolerance – Human Body Model	±2kV
Max Impressed Pressure(P1>P2).....	20kPa
Pressure Media	Non-corrosive gases

Electrical Characteristics (VDD=3V unless otherwise noted.)

Power Supply Characteristics						
Symbol	Parameter	Conditions	Min.	Typ.	Max.	Unit
V _{DD}	Operating Voltage	—	1.68	20 3.0	3.6	V
I _{DD}	Operating Current	—	—	0.6	1.2	mA
I _{STB1}	Standby Current	Temperature ≤ 85°C			250	nA
Pressure Output Characteristics						
Symbol	Parameter	Conditions	-10 Min.	— Typ.	Max.	Unit
P _{OP}	Operating Pressure	—	-20 -1000 -30	—	+1000	Pa
P _{RACC}	Relative Accuracy	P: +/- 1000 Pa, T: 0 ~ +50°C			+10	pa
P _{AACC1}	Absolute Accuracy 1	P: +/- 1000 Pa, T: +25 °C			+20	Pa
P _{AACC2}	Absolute Accuracy 2	P: +/- 1000 Pa, T: 0 ~ +50 °C			+30	Pa
ADC Characteristics						
Symbol	Parameter	Conditions	Min.	Typ.	Max.	Unit
P _{RES}	ADC Resolution	By internal option	—	20	—	bit
P _{SEN}	Pressure Sensitivity	—	—	0.0027	—	Pa/LSB
P _{RMS}	Pressure Resolution (RMS)	—	—	0.1	—	Pa
t _{ADC}	AD Conversion Time	—	—	1.7	—	ms
t _{update}	Data Update Time	Full measurement and temperature compensation	—	7	—	ms
t _{ST}	Start-Up Time	VDD ramp up to communication	—	—	1	ms
		VDD ramp up to Analog operation	—	—	2.5	ms
t _{SLP}	Wake-Up Time	Sleep to communication	—	—	0.5	ms
		Sleep to analog operation	—	—	2	ms



US633-F1K-T4

Differential Pressure Sensor With I²C

Interface/Frequency Characteristics						
Symbol	Parameter	Conditions	Min.	Typ.	Max.	Unit
F _{sys}	System Frequency	—	—	4	—	MHz
F _{I²C}	I ² C Clock Frequency	—	—	—	3.4	MHz

I²C Operation

The SS must be high after power on, and the first command must be I²C command, the I²C mode will be selected.

US633 supports a bi-direction two wire bus and data transmission protocol to output data. A processor sends data onto the bus is defined as transmitter, US633 receives data is defined receiver. The bus must be controlled by a master processor which generates the serial clock (SCL), controls the bus access, and generates the START and STOP conditions, while the US633 works as slave.

The following bus protocol has been defined:

- Data transfer may be initiated only when the bus is not busy.
- During data transfer, the data line must remain stable whenever the clock is HIGH level. Changes in the data line while the clock line is HIGH will be interpreted as a START or STOP condition.

Following bus conditions has been defined

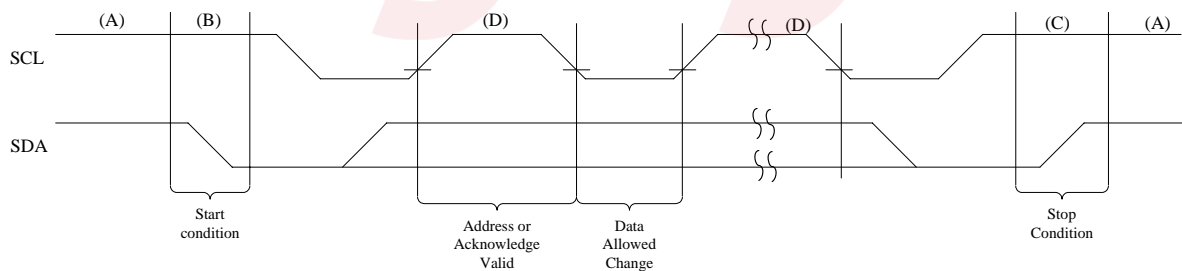

- Bus not busy as condition(A)
Both data and clock lines remain HIGH.
- Start data transfer as condition(B)
A HIGH to LOW transition of the SDA line while the clock (SCL) is HIGH determines a START condition. Reading data must be begun by START condition.
- Stop data transfer as condition(C)
A LOW to HIGH transition of the SDA line while the clock (SCL) is HIGH determines a STOP condition. All operation must be ended by a STOP condition.



US633-F1K-T4 Differential Pressure Sensor With I²C

- data valid as condition(D)
After a START condition, the data line is stable for the duration of the HIGH period of the clock signal. The data on the line must be changed during the LOW period of the clock signal. There is one clock pulse per bit of data. The number of valid data bytes transferred between the START and STOP conditions.
- Acknowledge signal
Each US633 receiving, when addressed, is obliged to generate an acknowledge after the reception of each byte. The processor must generate an extra clock pulse which is associated with this acknowledge bit. The US633 has to pull down the SDA line during the acknowledge clock pulse. The way is the SDA line is stable LOW during the HIGH period of acknowledge related clock pulse. A processor must signal an end of data to the slave by not generating an acknowledge bit on the last byte.
- US633 control address
The seven bit is as slave address after START condition. The US633 slave address is 1001100B (7 bits). The eighth bit of control address is read or written bit that processor wants. The processor read data sequence refers as below :

Start	Slave Address							R/W	SAK
	1	0	0	1	1	0	0	0/1	

I²C Command Format:

Writing one Byte to slave

Master	S	SAD+W <1001100 0>	Command		P
Slave (US633)		SAK	SAK		

Notation:

- * **S** **Start**
- * **P** **Stop**
- * **SAD+W** **Slave Address (1001 100) + Write bit (0)**
- * **SAD+R** **Slave Address (1001 100) + Read bit (1)**
- * **A** **Master acknowledge:** The microcontroller should respond a low signal to the US633.
- * **~A** **Master non-acknowledge:** The microcontroller should respond a high signal to the US633.
- * **SAK** **Slave acknowledge:** The US633 should respond a low signal to the microcontroller.



US633-F1K-T4

Differential Pressure Sensor With I²C

I²C reading format for pressure data:

Example: Full measurement command (0xAA, Force Mode)

After written a command (0xAA), the master will start to read pressure value through I²C interface.

Reading format as below:

Write 0xAA Command (Force Mode)				Conversion Time Delay		Read Pressure Data										
Master	S	SAD+W <1001100 0>	Command <10101010>	P	Delay >10ms	S	SAD+R <1001100 1>	Status <Bit 7:0>	A	Pressure Data < Bit 23:16 >	A	Pressure Data < Bit 15:8 >	A	Pressure Data < Bit 7:0 >	-A	P
Slave (US633)			SAK	SAK				SAK								

I²C Command

The command of pressure measurement as shown below:

Command	Description
0xAA _{Hex} (Force Mode)	(1) When the US633 is written a 0xAA _{Hex} , it will turn into force mode and start measurement pressure. (2) After pressure measurement is done, the US633 will turn into sleep mode automatically.

NOTE:

(1) Command Delay Time:

Before next command (0xAA) write to US633, the US633 must has a delay time is more than 10 ms for ADC conversion time, as show below:

Command Delay Time Diagram

Command_1 (0xAA)	ADC Conversion Time Delay 10ms	Read Status and Pressure Data	Command_2 (0xAA)	ADC Conversion Time Delay 10ms	Read Status and Pressure Data	Command_3 (0xAA)	Command_N (0xAA)
---------------------	-----------------------------------	----------------------------------	---------------------	-----------------------------------	----------------------------------	---------------------	-------	---------------------



US633-F1K-T4

Differential Pressure Sensor With I²C

Status Register Descriptions

STATUS			
Bit	Description	Attr	Default
7	Reserved	R	0
6	Power supply for ADC reference voltage: 1: Power on. 0: Power off.	R	0
5	Busy: 1: Measurement is active. 0: Sleep mode (Default after POR) * This bit is reset to zero automatically after pressure sensor measurement done in force mode.	R	0
4	Reserved	R	0
3	Reserved	R	0
2	Reserved	R	0
1	Reserved	R	0
0	Reserved	R	0



US633-F1K-T4

Differential Pressure Sensor With I²C

Pressure Measurement Operating Flow

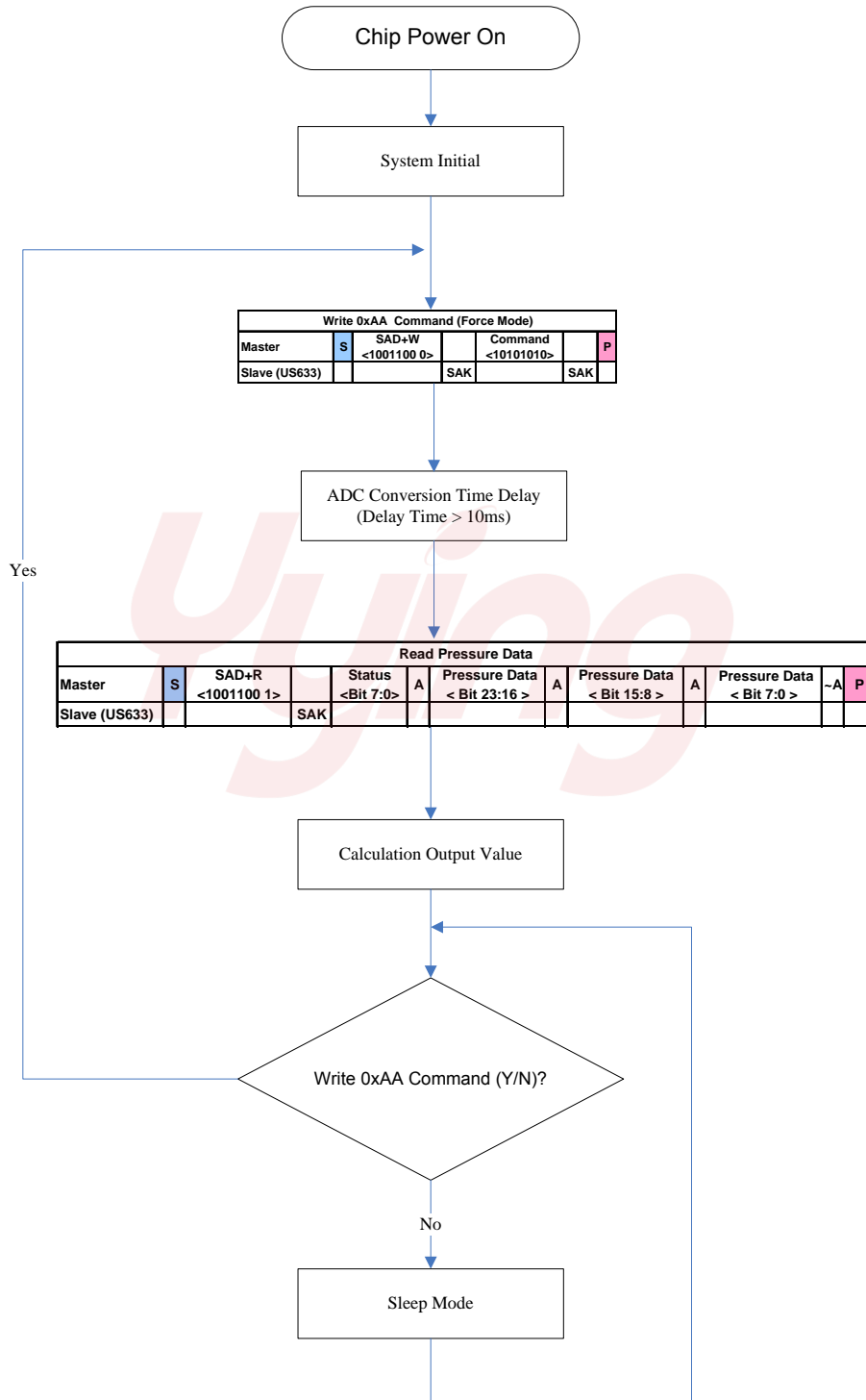

US633-F1K-T4

Differential Pressure Sensor With I²C

Differential Pressure versus digital out value

The relationship between digital output value and pressure is given as show below:

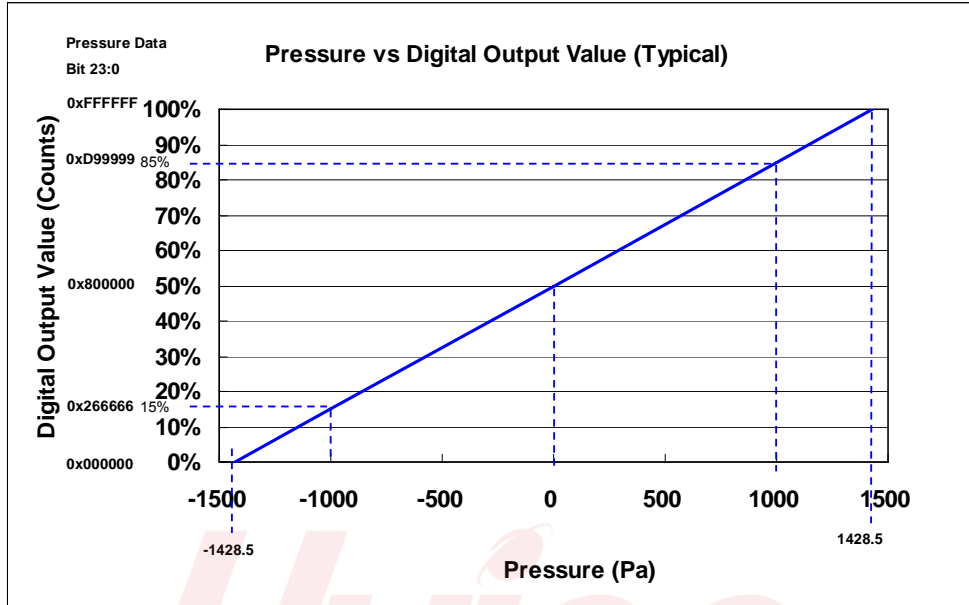

$$P_{out} \text{ (Pa)} = \frac{(\text{ADC Value}_{\text{Bit 23:0}} - 0x800000_{\text{HEX}}) * (0x07d0_{\text{HEX}})}{(0xb33333_{\text{HEX}})}$$

Application Circuit (For I²C Interface)

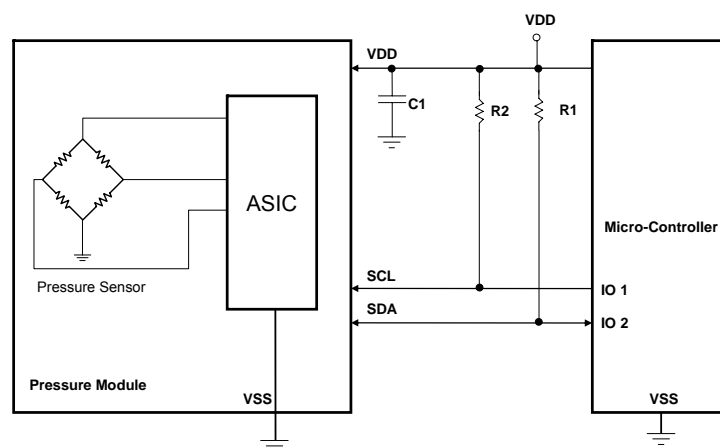

Fig. 1: I²C Application Circuit.

Note:

- (1) R1, R2: Pull-Up Resister. (4.7kΩ ~ 10kΩ, If needed.)
- (2) C1: 0.1uF.



US633-F1K-T4

Differential Pressure Sensor With I²C

Package Information

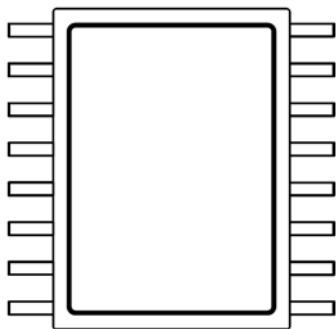
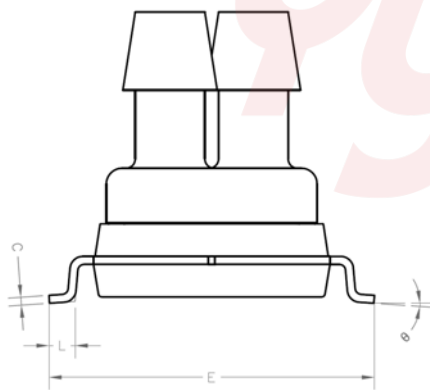
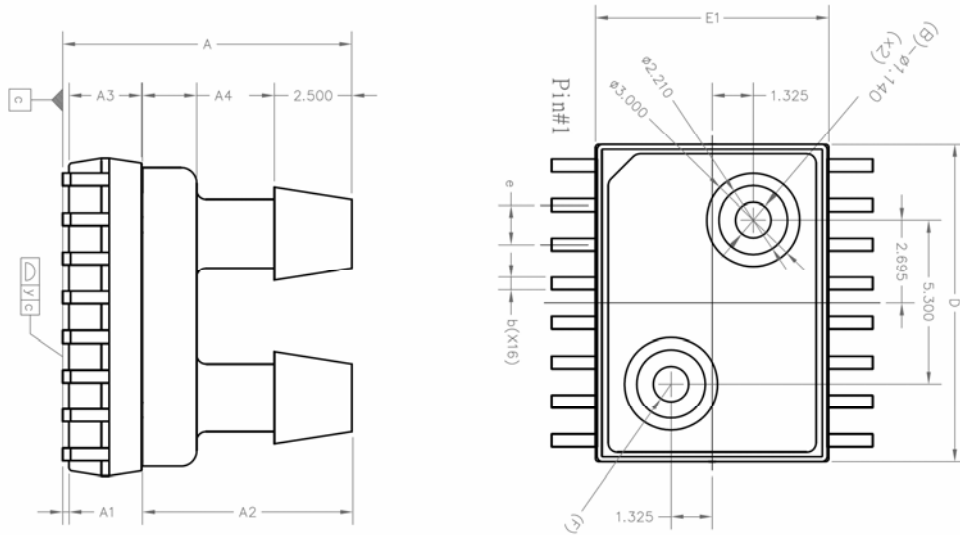

SYMBOLS	DIMENSIONS IN MILLIMETERS		
	MIN.	NOM.	MAX.
A	9.12	9.32	9.52
A1	0.00	0.19	0.25
A2	6.65	6.75	6.85
A3	2.23	2.337	2.43
A4	---	1.75 REF.	---
b	0.33	0.41	0.51
c	---	0.254 REF.	---
D	10.033	10.262	10.439
E	10.033	10.348	10.668
E1	7.420	7.520	7.620
e	---	1.27	---
L	0.38	0.81	1.27
y	---	---	0.076
θ	0°	---	8°



US633-F1K-T4

Differential Pressure Sensor With I²C

I²C Example Code

```
/** MAIN PRORGAM **
```

```
void main()
{
SYSTEM_INITIAL();           // IO(I2C Mode: SS Pin Output High) , LCM Display, Memory Initail
ms_DELAY(5);                // Delay 5ms
while (1)                   // Read pressure loop in force mode
{
    CMD_WRITE(0x98,0x0aa);   // Force Mode & Full Measurement.
    m s_DELAY(10);          // ADC Conversion Time Delay 10ms
    IIC_read _pressure(0x99); // Read Pressure data
}
}
```

```
/*******Sub-Program *****/
```

```
void CMD_WRITE(uint16_t sub_address,uint16_t wr_data)
```

```
{
//===== Slave Address + Bit 0 (write=0) =====
start();
    if((sub_address >>7) & 0x01) {SDA_DOUTSET;}
    else {SDA_DOUTCLR;} ; clock();
    if((sub_address >>6) & 0x01) {SDA_DOUTSET;}
    else {SDA_DOUTCLR;} ; clock();
    if((sub_address >>5) & 0x01) {SDA_DOUTSET;}
    else {SDA_DOUTCLR;} ; clock();
    if((sub_address >>4) & 0x01) {SDA_DOUTSET;}
    else {SDA_DOUTCLR;} ; clock();
    if((sub_address >>3) & 0x01) {SDA_DOUTSET;}
    else {SDA_DOUTCLR;} ; clock();
    if((sub_address >>2) & 0x01) {SDA_DOUTSET;}
    else {SDA_DOUTCLR;} ; clock();
    if((sub_address >>1) & 0x01) {SDA_DOUTSET;}
    else {SDA_DOUTCLR;} ; clock();
    if((sub_address >>0) & 0x01) {SDA_DOUTSET;}
    else {SDA_DOUTCLR;} ; clock();
    SACK();
}
```



US633-F1K-T4 Differential Pressure Sensor With I²C

```
//=====write data=====

    if((wr_data >>7) & 0x01) {SDA_DOUTSET;}
    else {SDA_DOUTCLR;} ; clock();
    if((wr_data >>6) & 0x01) {SDA_DOUTSET;}
    else {SDA_DOUTCLR;} ; clock();
    if((wr_data >>5) & 0x01) {SDA_DOUTSET;}
    else {SDA_DOUTCLR;} ; clock();
    if((wr_data >>4) & 0x01) {SDA_DOUTSET;}
    else {SDA_DOUTCLR;} ; clock();
    if((wr_data >>3) & 0x01) {SDA_DOUTSET;}
    else {SDA_DOUTCLR;} ; clock();
    if((wr_data >>2) & 0x01) {SDA_DOUTSET;}
    else {SDA_DOUTCLR;} ; clock();
    if((wr_data >>1) & 0x01) {SDA_DOUTSET;}
    else {SDA_DOUTCLR;} ; clock();
    if((wr_data >>0) & 0x01) {SDA_DOUTSET;}
    else {SDA_DOUTCLR;} ; clock();
    SACK();
    stop();
}

//=====//
```



US633-F1K-T4 Differential Pressure Sensor With I²C

```
void IIC_read_pressure (uint16_t read_address)
{
    status_reg=0; counts1=0;
    start(); // start condition
    //===== Slave Address + Bit 0(Read=1) =====
    if((read_address >>7) & 0x01) {SDA_DOUTSET;}
    else {SDA_DOUTCLR;} ; clock();
    if((read_address >>6) & 0x01) {SDA_DOUTSET;}
    else {SDA_DOUTCLR;} ; clock();
    if((read_address >>5) & 0x01) {SDA_DOUTSET;}
    else {SDA_DOUTCLR;} ; clock();
    if((read_address >>4) & 0x01) {SDA_DOUTSET;}
    else {SDA_DOUTCLR;} ; clock();
    if((read_address >>3) & 0x01) {SDA_DOUTSET;}
    else {SDA_DOUTCLR;} ; clock();
    if((read_address >>2) & 0x01) {SDA_DOUTSET;}
    else {SDA_DOUTCLR;} ; clock();
    if((read_address >>1) & 0x01) {SDA_DOUTSET;}
    else {SDA_DOUTCLR;} ; clock();
    if((read_address >>0) & 0x01) {SDA_DOUTSET;}
    else {SDA_DOUTCLR;} ; clock();
    SACK(); // master ack low
    SDA_IN ; // set sda input
    //=====Read status =====
    if (SDA==1 ) status_reg+=128;    clock();
    if(SDA==1 ) status_reg+=64;    clock();
    if (SDA==1 ) status_reg +=32;    clock();
    if (SDA==1 ) status_reg +=16;    clock();
    if (SDA==1 ) status_reg+=8;    clock();
    if (SDA==1 ) status_reg+=4;    clock();
    if (SDA==1 ) status_reg+=2;    clock();
    if (SDA==1 ) status_reg+=1;    clock();
    MACK();
```



US633-F1K-T4 Differential Pressure Sensor With I²C

```
//=====Read pressure Data Bit 23:16 =====
```

```
if (SDA==1 ) counts1+=0x800000;    clock();  
if(SDA==1 ) counts1+=0x400000;    clock();  
if (SDA==1 )) counts1+=0x200000;   clock();  
if(SDA==1 ) counts1+=0x100000;    clock();  
if (SDA==1 ) counts1+=0x080000;    clock();  
if (SDA==1 ) counts1+=0x040000;    clock();  
if (SDA==1 ) counts1+=0x020000;    clock();  
if (SDA==1 ) counts1+=0x010000;    clock();
```

```
//===== Read pressure Data Bit 15:8=====
```

```
MACK(); // master ack low
```

```
if(SDA==1 ) counts1+=0x8000;    clock();  
if (SDA==1 ) counts1+=0x4000;    clock();  
if (SDA==1 ) counts1+=0x2000;    clock();  
if (SDA==1 ) counts1+=0x1000;    clock();  
if (SDA==1 ) counts1+=0x0800;    clock();  
if (SDA==1 ) counts1+=0x0400;    clock();  
if (SDA==1 ) counts1+=0x0200;    clock();  
if (SDA==1 ) counts1+=0x0100;    clock();
```

```
MACK(); // master ack low
```

```
//===== Read pressure Data Bit 7:0=====
```

```
if (SDA==1 ) counts1+=0x80;    clock();  
if (SDA==1 ) counts1+=0x40;    clock();  
if (SDA==1 ) counts1+=0x20;    clock();  
if (SDA==1 ) counts1+=0x10;    clock();  
if (SDA==1 ) counts1+=0x08;    clock();  
if (SDA==1 ) counts1+=0x04;    clock();  
if (SDA==1 ) counts1+=0x02;    clock();  
if (SDA==1 )) counts1+=0x01;    clock();
```

```
NACK(); // master ack High
```

```
stop();
```



US633-F1K-T4 Differential Pressure Sensor With I²C

```
//=====Calculation Pressure output value =====//
Offset =0x800000;    // offset value
negative_flag= 0;    // clear negative_flag
if (counts1>= Offset)
{
// ===== Calculation pressure value , Display resolution : 0.1mmHg =====//
counts1= (counts1- Offset)* (0x07d0)*10/(0xb33333); }
else
{
counts1= ~(( Offset -counts1)*(0x07d0)*10/(0xb33333))+1; // Calculation negative pressure value
negative_flag= 1;
}
Display_Pressure(counts1, negative_flag);    // display pressure value
}
```





US633-F1K-T4 Differential Pressure Sensor With I²C

```
//=====//  
void start() // start condition //  
{  
  SDA_OUT; // SDA set to Output mode.  
  SDA_DOUTSET; // SDA Output high.  
  SCL_DOUTSET; // SCL Output high.  
  NOP_DELAY(30);  
  SDA_DOUTCLR; // SDA output low.  
  NOP_DELAY(30);  
  SCL_DOUTCLR; // SCL output low.  
  NOP_DELAY(30);  
}  
  
void stop()  
{  
  SDA_OUT; // SDA set to Output mode.  
  SDA_DOUTCLR;  
  SCL_DOUTCLR;  
  NOP_DELAY(30);  
  SCL_DOUTSET;  
  NOP_DELAY(30);  
  SDA_DOUTSET;  
  NOP_DELAY(30);  
}  
  
void clock()  
{  
  SCL_DOUTSET;  
  NOP_DELAY(2);  
  NOP_DELAY(2);  
  SCL_DOUTCLR;  
  NOP_DELAY(1);  
  NOP_DELAY(1);  
}
```



US633-F1K-T4 Differential Pressure Sensor With I²C

```
void MACK()
{
  SDA_OUT ;      // SDA set to output mode
  SDA_DOUTCLR;
  NOP_DELAY(30);
  clock();
  NOP_DELAY(30);
  SDA_IN ; // set sda input
  NOP_DELAY(30);
}

void NACK()
{
  SDA_OUT ;      // SDA set to output mode
  SDA_DOUTSET; // SDA output high
  NOP_DELAY(30);
  clock();
  NOP_DELAY(30);
}

void SACK()
{
  SDA_IN ; // SDA set to input mode
  NOP_DELAY(30);
  SCL_DOUTSET;
  NOP_DELAY(30);
  ack_error_flag=SDA_N; // read ACK Signal
  clock();
  NOP_DELAY(30);
  SDA_OUT;
  NOP_DELAY(30);
}

//=====End =====//
```